

103SCVFI090

Chariot

“A modern day chariot for today’s Aatmanirbhar warrior.”

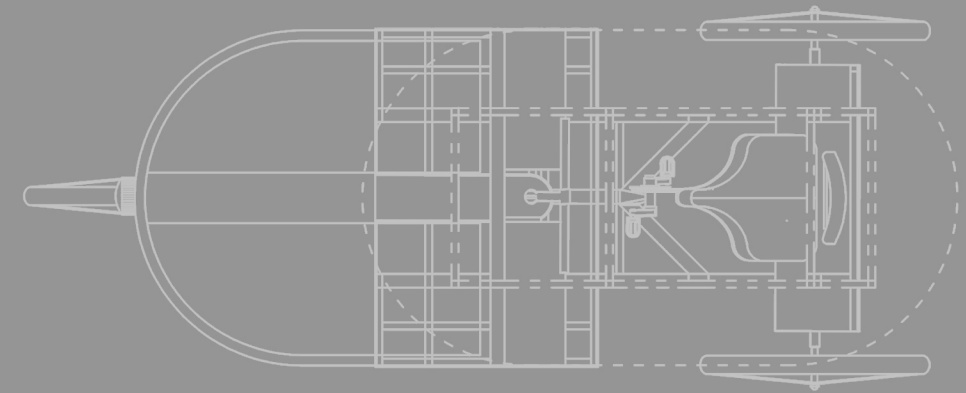
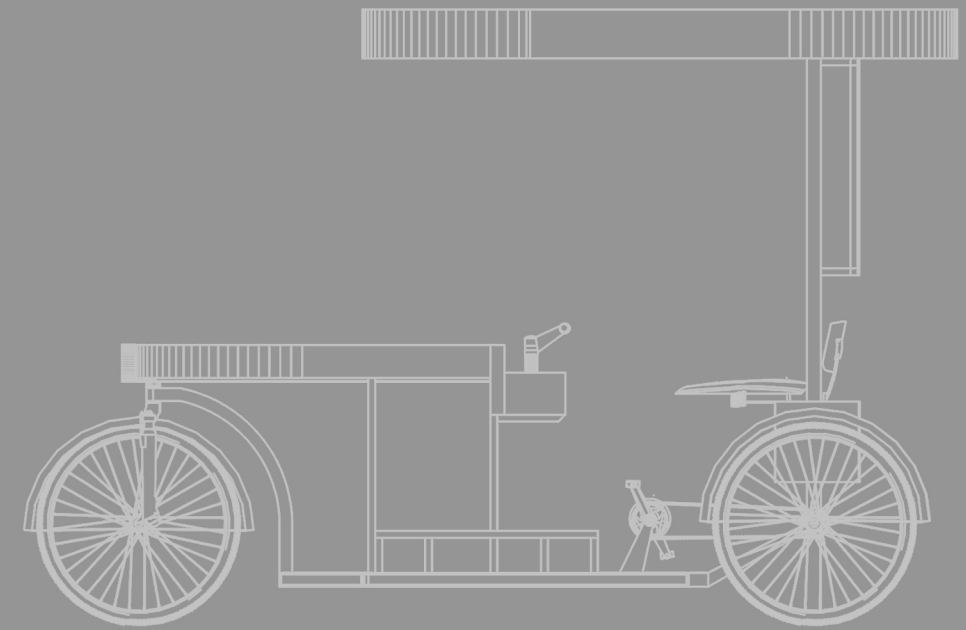

“Changing perception towards our fruit and vegetable vendors”

FRUITS AND VEGETABLE BUSINESS IN INDIA.

Nature of business

- Extremely localised and highly fragmented.
- Trading of farm produced fruits and vegetables.
- Highly perishable nature of goods
- Atleast 2 intermediaries present in the supply chain between farmers and consumers.



Cart Vendors/ Thelas/ Laaris

Cart vendors are traditional tier 1 or tier 2 resellers. They procure fruit and vegetables from the local wholesale markets or organized retailers. These vendors are a common sight pan India and they sell fruits and vegetables door to door on a cart (a wooden platform with 4 wheels attached).

They sometimes operate in group and purchase fresh produce of same type and sell them. Some vendors have a fixed spot others do not.

Traditional Supply Chain

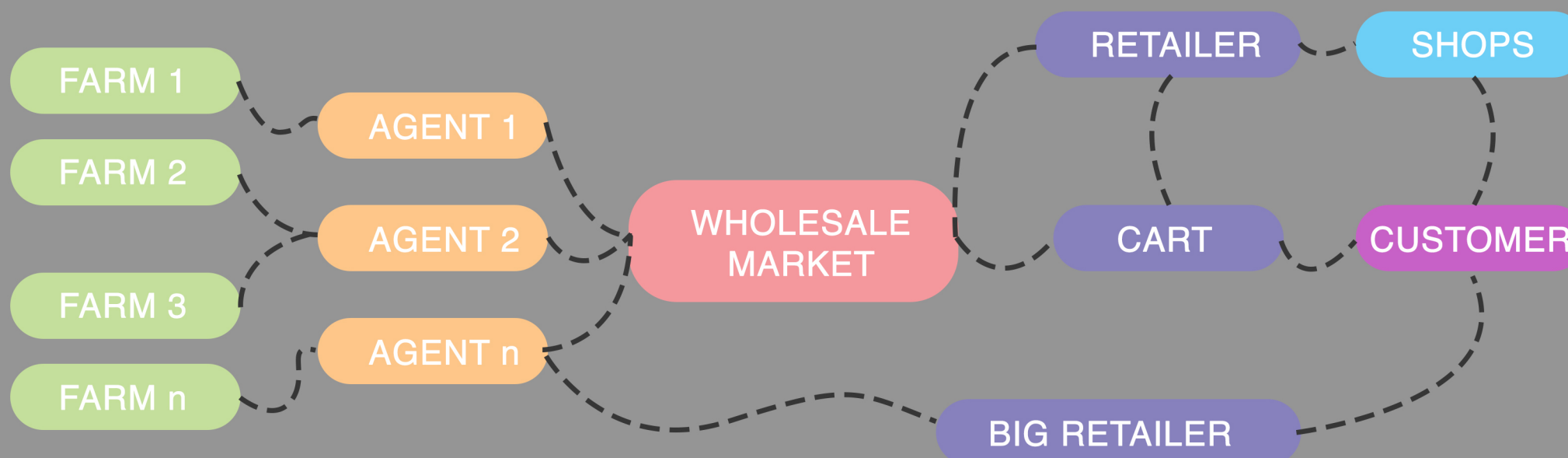

Inventory of a cart

SPACE OF A CART

- Platform size
6ft x 4ft approx
- No shade attached
- Shade attached
- Space under the platform



Unseasoned wood platform gets damaged easily

ITEM TYPE

- Only fruits
- Only Vegetables
- Mixed items



Crate being used as a chair for sitting

AMOUNT OF ITEM

- 1 or 2 Item in large quantities
- Mixed items but in smaller quantity



Stepped display for fruits. The cart is anchored with bicks used as pegs.



Vegetable vendor utilizing the street lamp for lighting.



Bare minimum tools (hammer, nails and saw) required to make the platform.



Lack of space utilization results toppling of fruits and vegetables .

Key Observations

Vendors sometimes use the space under the cart, although it is not designed for the use.

Cart vendors have their time slots fixed, i.e. they work in the morning hours before lunch or in evening hours before dinner.

Cart vendors having a fixed spot to sell for longer period of time.

Improper storage leads to wastage of goods.

Long hours of standing and no proper space for sitting. They sometimes carry a chair/ stool or use a basket. Even sit on the cart, if space is available.

They have to sprinkle water on vegetables to maintain moisture level. Sometimes they use gunny bags to cover the vegetables.

The carts can carry a load up to 150-200 KGs. This leads to a problem when the vendors had to lift the cart and take a turn. Repeated exercise could lead to muscle/ back injury.

The Design Highlights

The cart is designed to maximize mobility for the vegetable vendors from the market to their specific areas. Seasoned wood/ marine ply is used for woodwork and MS frames for the chassis.

The cart has a tray of size 5.5ft long X 4ft wide which can be slid to access the baskets which are protected under it. This provides more KGs of vegetable inventory at their disposal.

Vegetables that require less moisture can be placed on the top tray whereas vegetables that require an optimum moisture level can be stored under the tray in a bamboo/ rattan basket sprayed with water.

A polycarbonate shade is provided to protect the vendor from sun and rain. LED lighting is also provided which can light up the tray easily.

Storage for a battery and toolkit is provided under the driver's seat. Additionally, a headlamp, charging port is also provided.

2 lockable drawers are provided for cash, bags, sanitizers, gloves, etc.

The space above the drawers can be used to place the weighing machine.

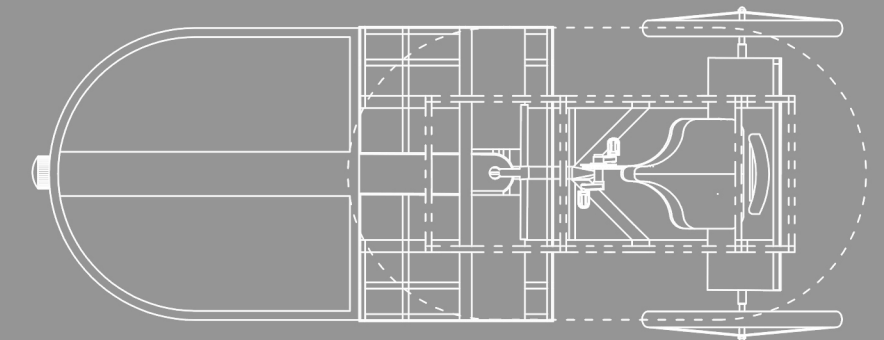
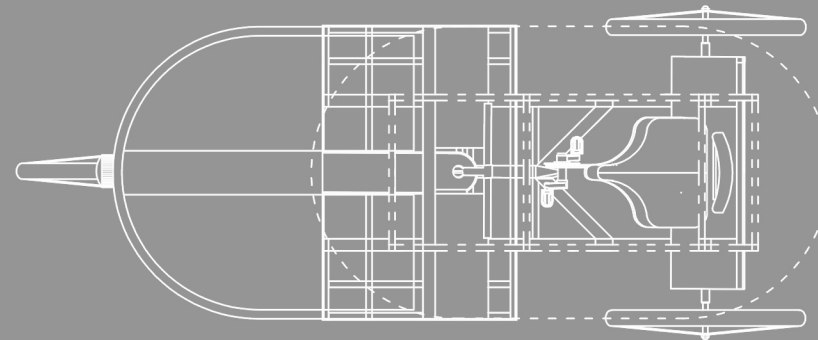
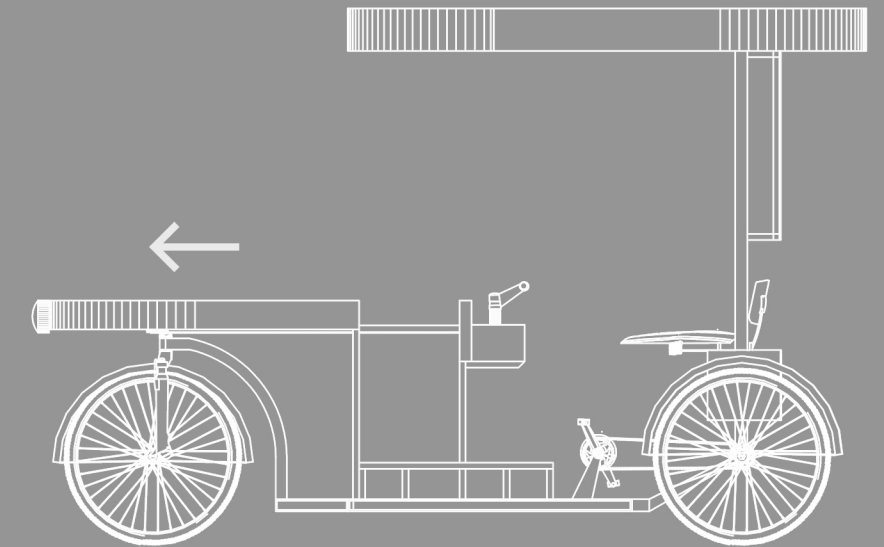
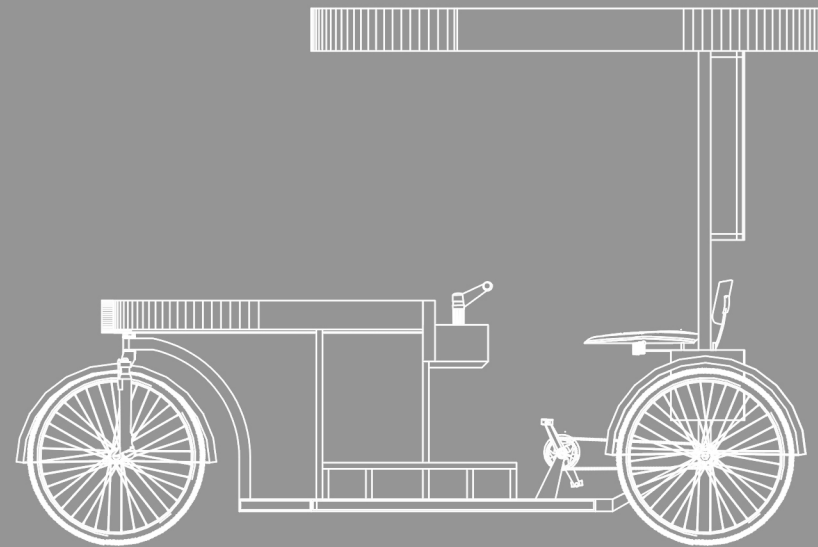

Normal Position

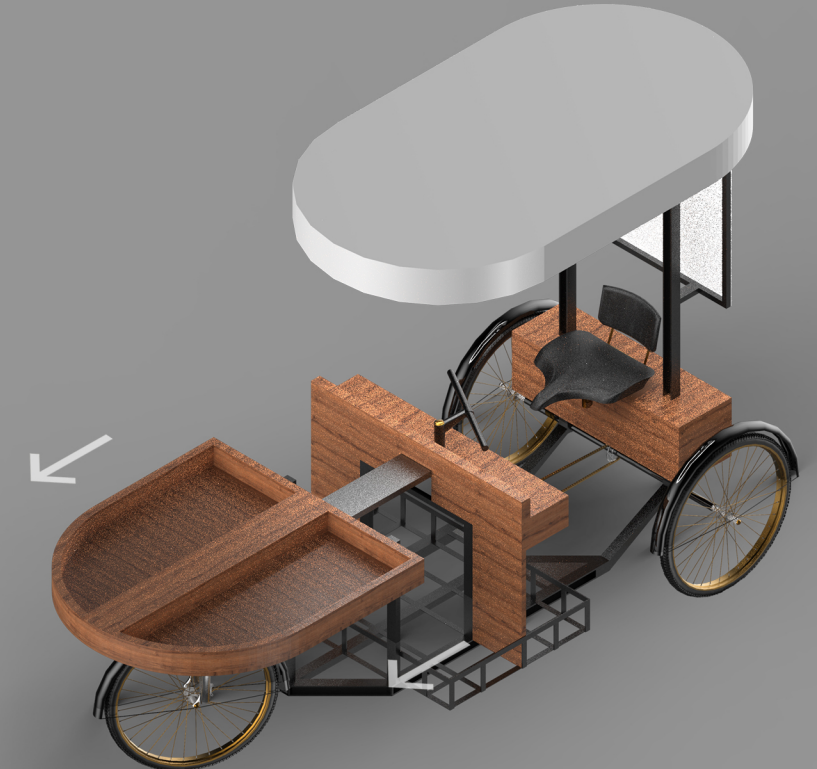

Expanded Position

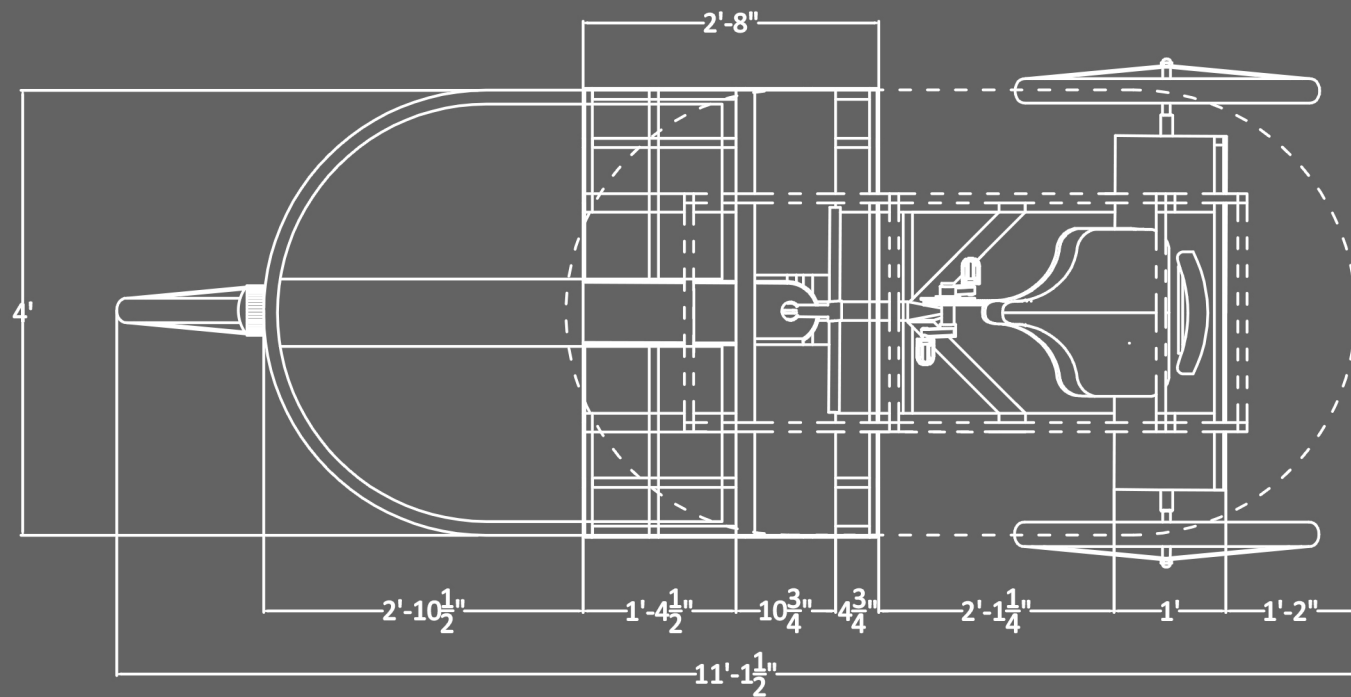

Top View

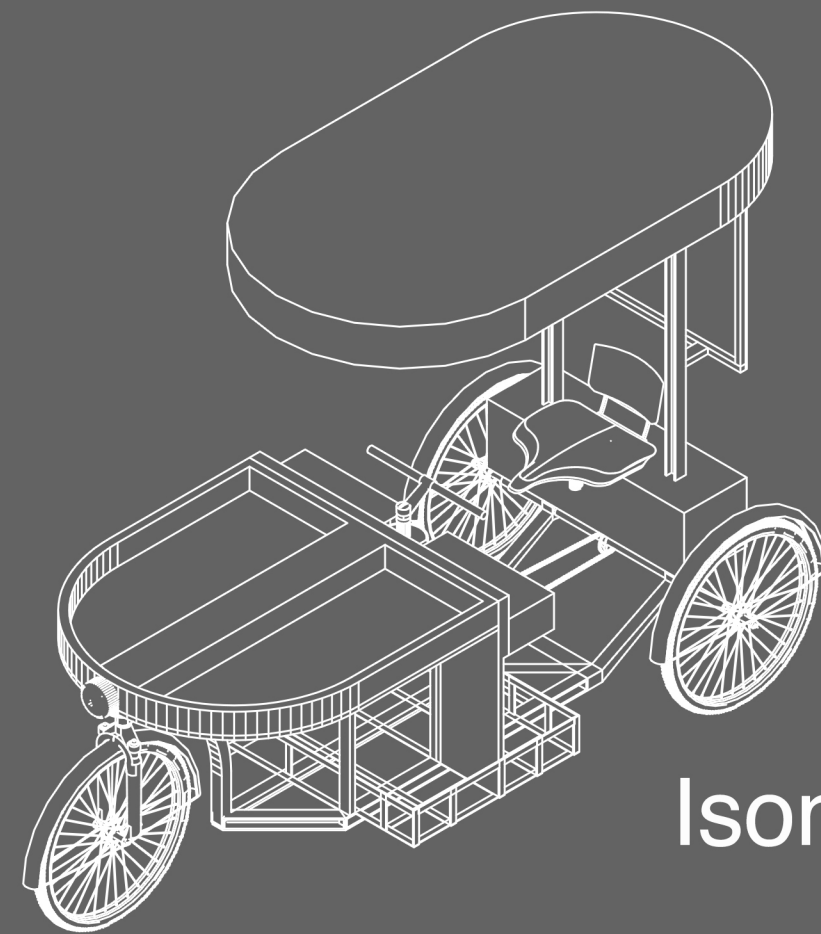

Isometric View

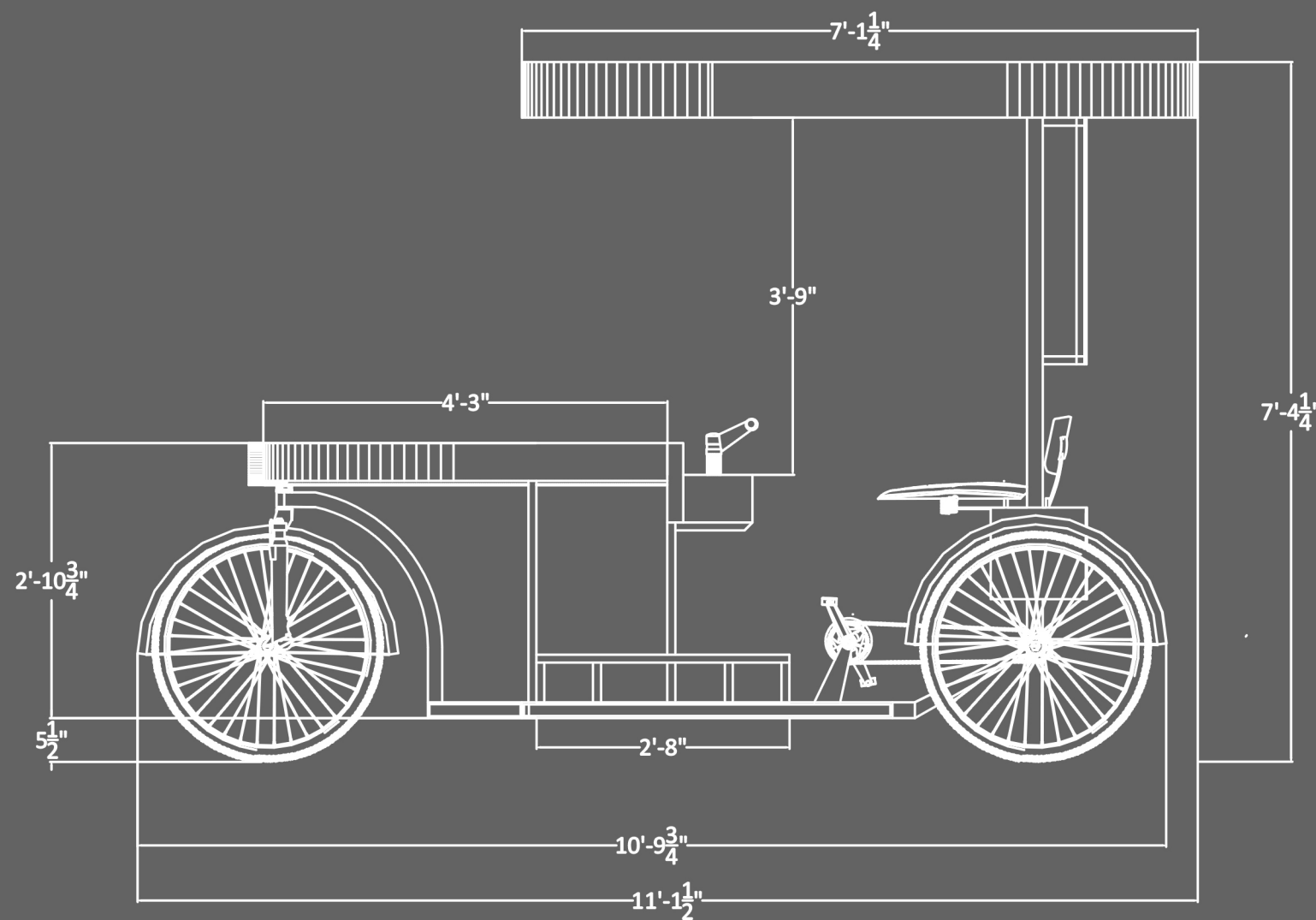

Side View

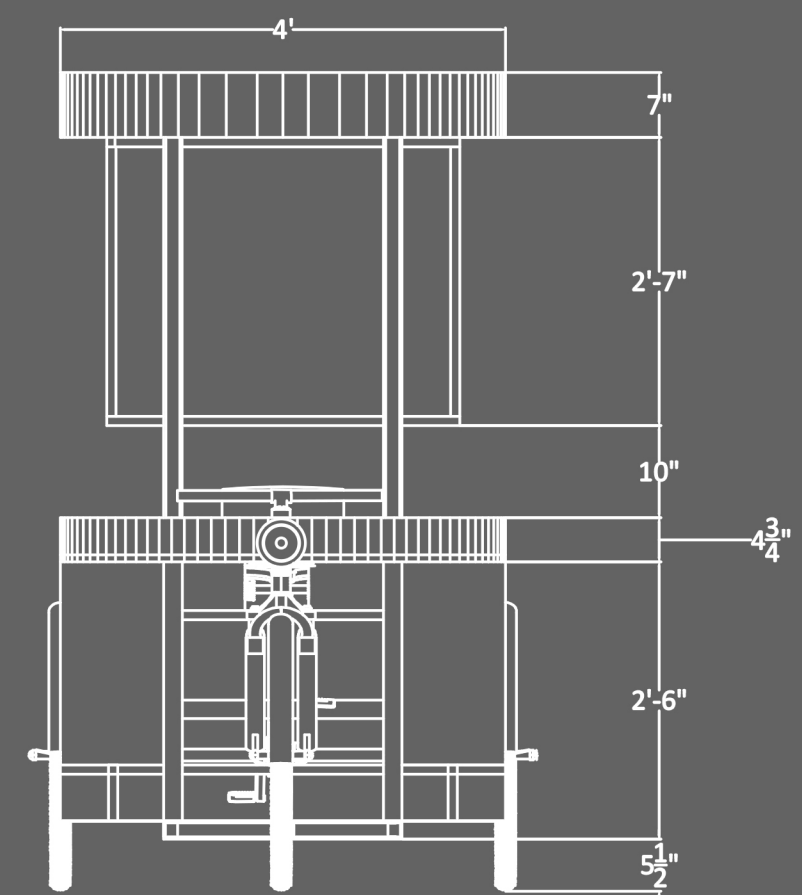

Front View

These carts provide a fresh look to the traditional Fruits and Vegetable distribution business. A business venture can be developed around manufacturing the carts locally. Additionally, a startup can be initiated where the organization is directly sourcing from the farmers/ agents and selling directly to the consumers at their doorstep.

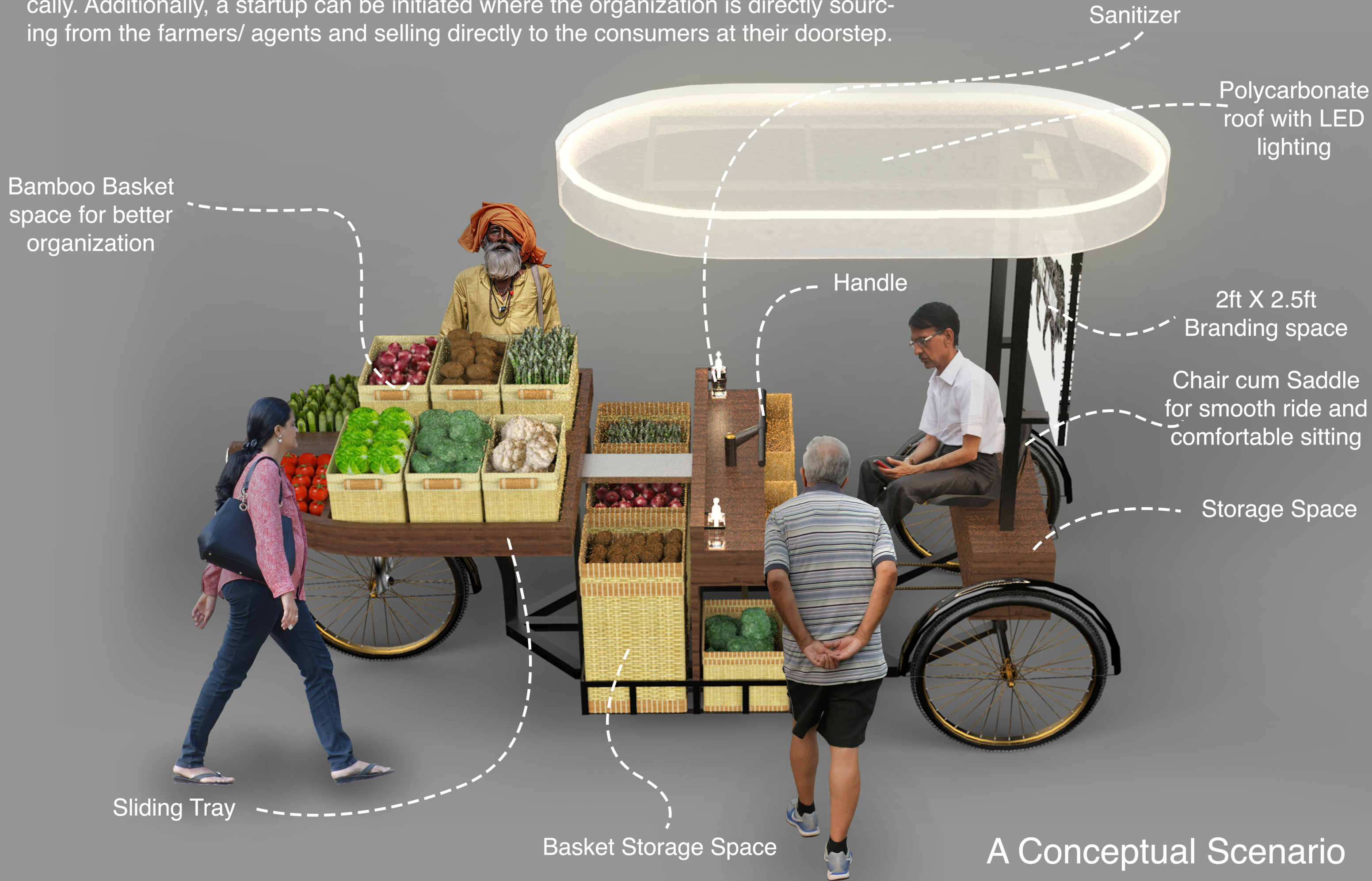

Sanitizer

Polycarbonate roof with LED lighting

Bamboo Basket space for better organization

Handle

2ft X 2.5ft Branding space

Chair cum Saddle for smooth ride and comfortable sitting

Storage Space

Sliding Tray

Basket Storage Space

A Conceptual Scenario